



Installation, Operation, and Maintenance Manual

Advantage® Compact Stainless Actuator



ITT

ENGINEERED FOR LIFE





Table of Contents

Introduction and Safety	2
Safety message levels	2
User health and safety	2
Transportation and storage	5
Handling and unpacking guidelines	5
Storage, disposal, and return requirements	5
Product Description	6
Actuator identification	6
Bonnet description	7
Valve diaphragm identification	7
Installation	9
Installation and Maintenance	9
Precautions	9
Install the valve and topworks	9
Change the compressor, tube nut, and snap ring	10
Mount the topworks to the valve	11
Tighten the bonnet fasteners	11
Fastener torque table for valve body to topworks	12
Actuator operating pressure	12
Inspection	12
Disassemble the valve	12
Replace the valve diaphragm	13
Parts Listings and Cross-Sectionals	16
Parts Listing and Cross-Sectional Drawings	16
ACS actuator	16

Introduction and Safety

Safety message levels

Definitions

Safety message level	Indication
 DANGER:	A hazardous situation which, if not avoided, will result in death or serious injury
 WARNING:	A hazardous situation which, if not avoided, could result in death or serious injury
 CAUTION:	A hazardous situation which, if not avoided, could result in minor or moderate injury
 Electrical Hazard:	The possibility of electrical risks if instructions are not followed in a proper manner
NOTICE:	<ul style="list-style-type: none"> • A potential situation which, if not avoided, could result in an undesirable result or state • A practice not related to personal injury

User health and safety

General precautions

This product is designed and manufactured using good workmanship and materials, and meets all applicable industry standards. This product should be used only as recommended by ITT.



WARNING:

- Misapplication of the valve can result in injury or property damage. Select valves and valve components of the proper materials and make sure that they are consistent with your specific performance requirements. Incorrect application of this product includes but is not limited to:
 - Exceeding the pressure or temperature rating
 - Failing to maintain this product according to the recommendations
 - Using this product to contain or control media that is incompatible with the materials of construction
 - Proper containment or protection from hazardous media must be provided by the end user to protect employees and the environment from valve discharge.
- If the product exhibits any indication of leakage, do not operate. Isolate the product and either repair it or replace it as outlined within this manual.
- This actuator should not be disassembled due to live spring loads in the actuator chamber. Only compressor and diaphragm attachment systems have serviceable parts.

Qualifications and training

The personnel responsible for the assembly, operation, inspection, and maintenance of the valve must be appropriately qualified. The operating company must do the following tasks:

- Define the responsibilities and competency of all personnel handling this equipment.
- Provide instruction and training.
- Ensure that the contents of the operating instructions have been fully understood by the personnel.

Instruction and training can be carried out by either ITT or the reseller of the valve by order of the operating company.

Non-compliance risks

Failure to comply with all safety precautions can result in the following conditions:

- Death or serious injury due to electrical, mechanical, and chemical influences
- Environmental damage due to the leakage of dangerous materials
- Product damage
- Property damage
- Loss of all claims for damages

Operational safety precautions

Be aware of these safety precautions when operating this product:

- Do not leave hot or cold components of the product unsecured against contact if they are a source of danger.
- Do not hang items from the product. Any accessories must be firmly or permanently attached.
- Do not use the product as a step or hand hold.
- Do not paint over the identification tag, warnings, notices, or other identification marks associated with the product.
- PTFE diaphragms emit toxic fumes due to thermal decomposition at temperatures of 380°C | 716°F or greater.
- Allow ample clearance for indicating spindle travel.
- Do not actuate cylinder without diaphragm in place.
- Use eye protection when working with compressed air and pressurized fluids.
- Do not operate if dents or cracks are present on the pressure chamber.
- Use proper personal protective equipment when handling after autoclave or in line high temperature operation.
- Fail open actuators lower air port should be left unobstructed or breather vents installed.
- Do not autoclave above 134°C | 273°F.

Maintenance safety precautions

Be aware of these safety precautions when performing maintenance on this product:

- You must decontaminate the product if it has been exposed to harmful substances such as caustic chemicals.
- Work on externally actuated valves should only be performed when the valve is removed from service.
- On completion of work, all safety and protective equipment must immediately be fitted again or reactivated.
- Before the re-operation, pay attention to the points in the following sections.
- The ACS actuator is not intended for submersion. Clean out of Place-COP processes should be limited to wipe down procedures.
- This product contains PTFE components that may omit toxic fumes if burned.

Use of unauthorized parts

Reconstruction or modification of the product is only permissible after consultation with ITT. Genuine spare parts and accessories authorized by ITT serve to maintain safety. Use of non-genuine ITT parts can annul liability of the manufacturer for the consequences. ITT parts are not to be used in conjunction with products not supplied by ITT as this improper use can annul all liability for the consequences.

The use of diaphragms other than genuine ITT diaphragms violates diaphragm valve industry standard MSS SP-88. Valve pressure, temperature, and overall performance can not be guaranteed.

Unacceptable modes of operation

The operational reliability of this product is only guaranteed when it is used as designated. The operating limits given on the identification tag and in the data sheet may not be exceeded under any circumstances. If the identification tag is missing or worn, contact ITT for specific instructions.

Transportation and storage

Handling and unpacking guidelines



CAUTION:

Always observe the applicable standards and regulations regarding the prevention of accidents when handling the product.

Handling guidelines

Follow these guidelines when handling the product to prevent damage:

- Use care when handling the product.
- Leave protective caps and covers on the product until installation.

Unpacking guidelines

Follow these guidelines when unpacking the product:

1. Inspect the package for damaged or missing items upon delivery.
2. Note any damaged or missing items on the receipt and freight bill.
3. Do not lift or pull on the electrical conduit lines. Doing so may cause the POC switches to come out of calibration.

Storage, disposal, and return requirements

Storage

If you are not immediately installing the product after delivery, store it as follows:

- Store the product in a dry room that maintains a constant temperature.
- Make sure that the products are not stacked on top of one another.

Disposal

Dispose of this product and associated components in compliance with federal, state, and local regulations.

Return

Ensure these requirements are met before you return a product to ITT:

- Contact ITT for specific instructions on how to return the product.
- Clean the valve of all hazardous material.
- Complete a Material Safety Data Sheet or Process Data Sheet for any process fluid that could remain on the valve.
- Obtain a Return Material Authorization from the factory.

Product Description

Actuator identification

Model number

An ACS model number contains the following:

Table 1: Actuator

Code	Description
ACS	Advantage Compact Stainless actuator

Table 2: Mode of operation

Code	Description
1	Fail open
2	Fail close with 90# spring
3	Double acting
1S	Fail open (sealed bonnet)
2S	Fail close with 90# spring (sealed bonnet)
3S	Double acting (sealed bonnet)

Table 3: Model number examples

Model number	Description
ACS2	Advantage Compact Stainless actuator, fail close with 90# spring
ACS3S	Advantage Compact Stainless actuator, double acting (sealed bonnet)
ACS1-AOS	Advantage Compact Stainless actuator, fail open with Adjustable opening stop

Identification tag

The model number is located on the ITT identification tag.

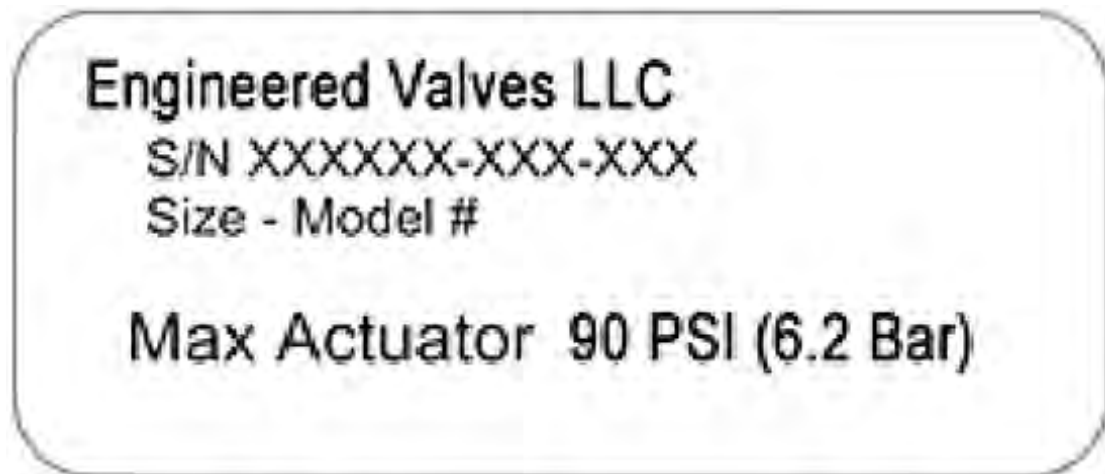

Figure 1: Identification tag

Line	Description
1	Valve serial number
2	Valve size and model number
3	Maximum recommended actuation pressure

Bonnet description

Non-Sealed bonnet

The non-sealed bonnet has a weep hole that indicates a diaphragm failure by allowing process fluid that accumulates in the bonnet to pass through the hole.

Sealed bonnet

The sealed bonnet uses a special “V-notch” vent plug, which permits leak detection.

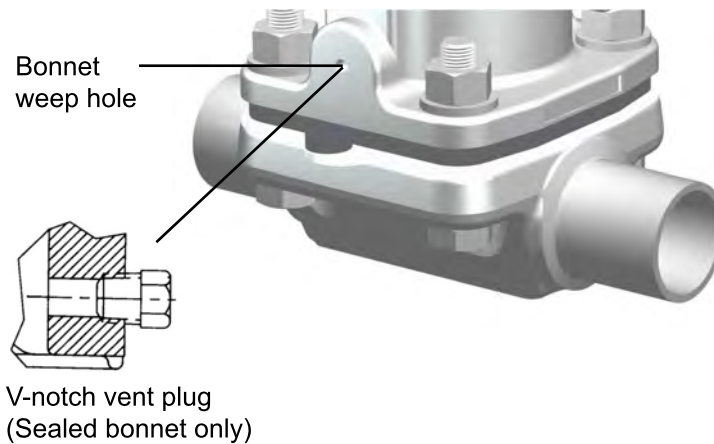

Figure 2: Weep hole and V-notch vent plug

Valve diaphragm identification

Diaphragm tab codes

All diaphragm materials and physical properties are batch traceable via permanent codes molded into the diaphragm tabs. The molding date, grade of diaphragm, and size provide traceability to original batch records.



1. Date code
2. Supplier code

Figure 3: Elastomer diaphragm front



1. Valve size
2. Grade of diaphragm

Figure 4: Elastomer diaphragm back



1. Material code
2. Date code

Figure 5: PTFE diaphragm

Installation

Installation and Maintenance

Precautions

WARNING:

- All procedures must be performed by qualified personnel.
- When the process fluid is hazardous, thermal (hot or cold), or corrosive, take extra precautions. Employ the appropriate safety devices and be prepared to control a process media leak.
- Always wear protective clothing and equipment to safeguard the eyes, face, hands, skin, and lungs from the fluid in the line.
- Do not disassemble the actuator in the field. The actuator contains energized springs which can cause injury. The product is designed to be recycled in its entirety.

CAUTION:

- Disconnect electrical, pneumatic, and hydraulic power before servicing actuator or automation components.

Install the valve and topworks

NOTICE:

The topworks size and configuration can limit the actual operating pressure. Consult the Pure-Flo catalog for pressure limitations. Consult the factory or engineering catalog for vacuum operation.

Consider the following information before installing the actuator:

- The maximum valve operating pressure is 10.34 bar | 150 psig. This pressure is applicable up to 38°C | 100°F. Valves at maximum pressure cannot be used at maximum temperatures.
 - The maximum actuator pressure is 6.2 bar | 90 psi.
1. If you have a weld end valve, then consider the following:

If you are welding ...	Then ...
Manually	Remove the topworks.
In line for schedule 10 or heavier pipe	Remove the topworks.
In line for schedule 5 or lighter pipe and tubing	You can weld with automatic equipment. Before you perform the weld: <ol style="list-style-type: none"> 1. Remove the topworks (optional). 2. If left installed, set the valve to the open position. 3. Properly purge the valve with an inert gas.

2. Install the valve.
Install with the raised hash marks (castings) or small machined dots (forgings) on the valve body at the 12 o'clock position to achieve the optimum drain angle.



3. Prior to pressurization (with the valve slightly open), tighten the bonnet fasteners. For more information, see [Tighten the bonnet fasteners](#) (page 11).
4. Connect the air line.
Connection size is 1/8" NPT.

NOTICE:

Air line connections should be made with care so as not to damage the actuator covers.

5. Cycle the valve two to three times to verify smooth operation.

Change the compressor, tube nut, and snap ring

To switch diaphragm types between EPDM and PTFE, the tube nut must be changed. Follow the steps below before you switch diaphragm types.

1. Insert a screw driver or similar thin blade between compressor and bonnet flange.



Figure 6: Remove the compressor

2. Apply light pressure to back side of compressor finger.
3. Remove compressor and snap ring assembly.



Figure 7: Compressor assembly

4. Replace with new snap ring, tube nut and compressor (only 0.5 & 0.75" sizes). Do not reuse snap ring.

Mount the topworks to the valve

1. Regulate the air pressure

If the topworks is ...	Then regulate the air pressure ...
ACS1, ACS1S, ACS3, ACS3S	In the upper cover to extend the compressor.
ACS2, ACS2S	In the lower cover to properly position the valve diaphragm.

2. Install the valve diaphragm.
For more information, see [Replace the valve diaphragm](#) (page 13).
3. Assemble the valve body and tighten the bonnet fasteners.
For more information, see [Tighten the bonnet fasteners](#) (page 11).

Tighten the bonnet fasteners



CAUTION:

Do not tighten fasteners while the system is pressurized or at elevated temperatures (greater than 38°C | 100°F).

1. Depressurize the system.
2. Use regulated air pressure to position diaphragm so that valve is slightly open.
You may need to use air pressure to actuate the valve.
3. Tighten the bonnet fasteners in a crisscross pattern.
For more information, see [Fastener torque table for valve body to topworks](#) (page 12).
4. Make multiple crisscross passes to build up torque to the final table value. Make additional crisscross passes using final table values to evenly tighten each fastener to within 5% of torque value.
5. Retighten the bonnet fasteners as noted above at ambient conditions after the system has cycled through operating pressure and temperature.
6. Monitor the valve for leakage:

If leakage ...	Then ...
Occurs at the body/bonnet flange sealing area	Depressurize the system and retighten the bonnet fasteners as noted above.
Continues	Depressurize the system and retighten the bonnet fasteners as noted above. (maximum 3rd re-torque)
Continues	Replace the valve diaphragm.

For more information, see [Replace the valve diaphragm](#) (page 13).

Fastener torque table for valve body to topworks

Values given are for lubricated fasteners.

Valve size		Bolt size		PTFE diaphragm		Elastomer diaphragm	
DN	Inch	Metric	Imperial	N-m	in-lb	N-m	in-lb
15	0.50	M6	1/4"	2.8-6.8	25-60	2.3-4.5	20-40
20	0.75	M6	1/4"	5.7-9.1	50-65	2.3-5.7	20-50
25	1.00	M8	5/16"	7.4-11.3	65-90	5.1-7.9	45-70
40	1.50	M10	3/8"	23-25	200-225	8.5-14.7	75-130
50	2.00	M12	7/16"	25-31	225-275	11-20	100-180

Actuator operating pressure

Maximum permitted air supply pressure

bar	kPA	psi
6.2	620	90

Actuator pressure rating

The actuator will withstand pressures well in excess of the rated pressure without risk of bursting. Maintaining operating pressure at or below the pressure rating will ensure optimum life of the operating components.

bar	kPA	psi
6.2	620	90

Inspection

The actuator cannot be disassembled and reassembled.

Inspection area	What to look for	Action if problem is found
External valve parts	Excessive wear or corrosion	<ul style="list-style-type: none"> Replace the affected parts (compressor, snap ring, tube nut) Contact ITT to obtain replacement parts or for specific instructions
Non sealed bonnet	Fluid weeping from the plug	Replace the valve diaphragm
Sealed bonnet	Fluid weeping from the plug Loosen the v-notch vent plug 2-3 turns to check	Replace the valve diaphragm
Actuator's bonnet weep hole and air ports	Air pressure	Contact ITT for specific instructions
Topworks	Spindle binding, excessive noise, or dried lubricant	Contact ITT for specific instructions
Diaphragm and valve body	Leakage between the diaphragm and valve body	Tighten the bonnet fasteners

For more information, see:

- [Replace the valve diaphragm](#) (page 13)
- [Tighten the bonnet fasteners](#) (page 11)

Disassemble the valve

1. Remove all line pressure.
2. If the actuator mode of operation is fail open or fail close, then load the actuator with air.

If the actuator mode of operation is ...	Then ...
Fail open	Load the actuator with sufficient air to partially close the valve.
Fail close	Load the actuator with sufficient air to partially open the valve.

3. Remove the bonnet fasteners.

4. Lift the topworks assembly from the valve body.
5. If the actuator mode of operation is fail open, then remove pressure load from the actuator.

Replace the valve diaphragm

1. Disassemble the valve.
For more information, see [Disassemble the valve](#) (page 12).
2. Unscrew the diaphragm from the compressor by turning the diaphragm counterclockwise. The replacement diaphragm should be identical in size and grade to the original diaphragm.
3. If replacing a PTFE diaphragm, then follow these steps.
 - a) Install the new elastomer backing cushion over the tube nut.



- b) Invert the PTFE diaphragm by pressing the center of the diaphragm face with your thumbs while holding the edge of the diaphragm with your fingers.



- c) Engage the threads of the diaphragm into the tube nut by rotating clockwise.



- d) Continue rotating the PTFE diaphragm clockwise into the compressor while securing the backing cushion from rotating.



4. Rotate the diaphragm until hard stop or heavy resistance is achieved and additional force does not significantly rotate the diaphragm into the compressor.



5. If replacing a PTFE diaphragm, re-invert the diaphragm.



6. If the actuator mode of operation is fail open or fail close, select one of these steps.

If the actuator mode of operation is ...	Then ...
Fail open	Reduce the air pressure until the back of the diaphragm is flat against the bonnet.

If the actuator mode of operation is ...	Then ...
Fail close	<ol style="list-style-type: none"><li data-bbox="665 239 1508 267">1. Connect the air line to the bonnet's cylinder.<li data-bbox="665 267 1508 334">2. Load the chamber with sufficient air to move the diaphragm upward until the back of diaphragm is flat against the bonnet. Do not apply excessive air pressure that results in inversion of the diaphragm.

7. For more information, see [Tighten the bonnet fasteners](#) (page 11).
8. If the actuator mode of operation is fail open, then release the air, allowing the valve to open.

Parts Listings and Cross-Sectionals

Parts Listing and Cross-Sectional Drawings

ACS actuator

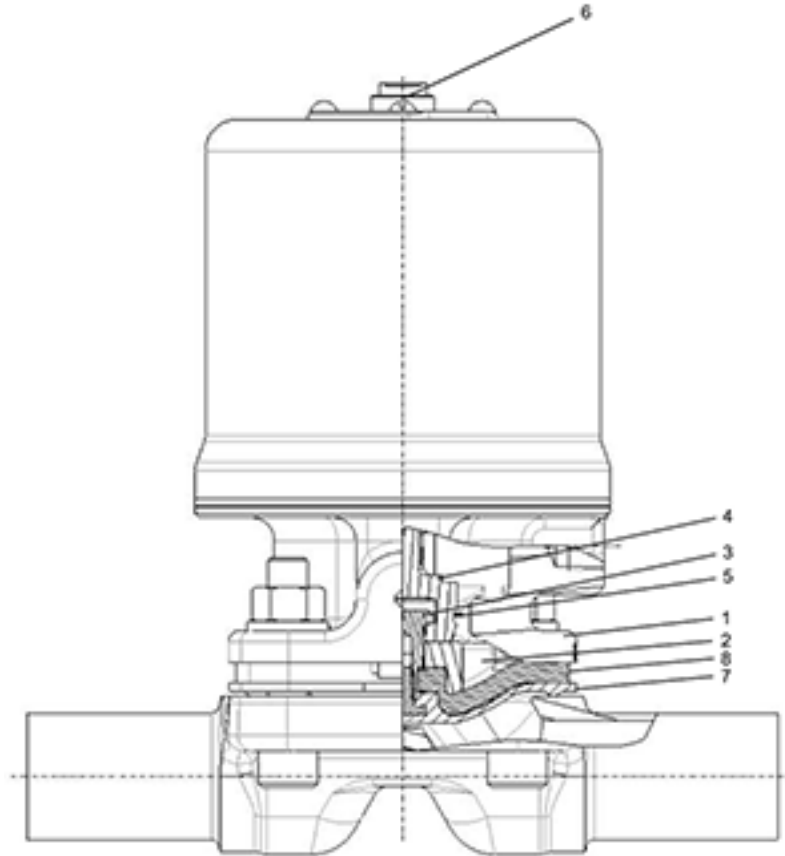

Figure 8: Cross section

Item	Description	Material	Quantity
1	Bonnet	Stainless steel	1
2 ¹	Compressor	Stainless steel	1
3 ¹	Tube nut (PTFE and Elastomer)	Stainless steel	1
4	Spindle	Stainless steel	1
5 ¹	Snap ring	Stainless steel	1
6	Indicating spindle	Stainless steel	1
7 ¹	Diaphragm	As required	1
8 ¹	Backing cushion	As required	1

¹ Recommended spare part

Visit our website for the latest version of this document and more information:
www.engvalves.com



ENGINEERED FOR LIFE

ITT Engineered Valves
33 Centerville Road
Lancaster, PA 17603
USA

ITT Industries Ltd.
Weycroft Avenue, Millwey Rise Industrial Estate
Axminster EX13 5HU
United Kingdom